

# The Tri-ang - Lego & LGB Crossover!

*By James Day*

Nothing acute or obtuse about this..... hopefully!

For some years I have had a distant interest in the Lego Train System. I had one when I was a child, loved it and played with it endlessly.



[http://4.bp.blogspot.com/\\_ixBDP53ERkM/TCT8rivnPYI/AAAAAAAAABJw/rbR9dnHiKhQ/s1600/VintageLegos1.jpg](http://4.bp.blogspot.com/_ixBDP53ERkM/TCT8rivnPYI/AAAAAAAAABJw/rbR9dnHiKhQ/s1600/VintageLegos1.jpg)

*I never had anything quite as extensive as this, but my first train was like the one entering the view from the left! The words on the sides my coach were London, Newcastle and Edinburgh! Just like the real thing? Well the loco was blue, but not that streamlined!*

Mine was battery powered and had a massive great battery box that took three HP11s (C cells in today's parlance) and this sat on top of the motor block, to represent the pannier tanks and boiler. It came with a bogie coach and bogie mail van. It was apparently based on the East Coast Mainline according to the destination boards on the coach!

I got a second motor and battery box a year or so later and built an identical loco! Even as a child I liked my standardisation! The best loco I had was the 'Electronic' tender loco which stopped or started when you blew a whistle.



<http://www.brickshelf.com/gallery/Sinner/Town/Misc/013.jpg>

*The Lego Electronic loco. Mine just stopped and started but I have since found out that a later version could reverse too!*

I had some signals too and these came with a small brick sized module that you plugged in under the rear of the loco. You also had to insulate the motor from the battery box with a piece of paper or tape and bring the supply into the new module with wires, however once you had done it, the train would stop if the signal was set at danger and you could re-start it by re-setting the signal! I liked that!

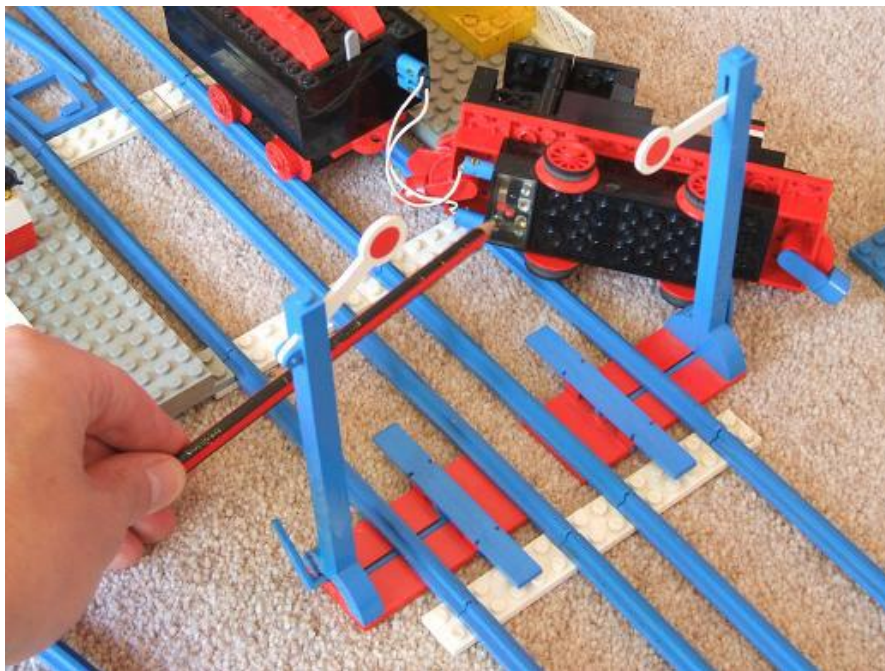

<http://www.brickshelf.com/gallery/XrisL/Train/lr2807.jpg>

*No it hasn't crashed! Someone is helpfully pointing a pencil at the signal control module, that stopped the train when it came into contact with the ramp on the signal. If you raised the signal arm, the ramp would lower and the train would re-start. I really liked the idea of signals serving a purpose; perhaps this was what gave me my taste for automation?*

I grew out of Lego in the early 70s and it was all packed away and eventually found its way into the hands of a genuine Lego collector who appreciated it very much.

However in 1980 a friendly local dealer allowed me to attend the Toy Fair in London, which was a very interesting experience indeed. That was the year that Lego launched the new version of the train with grey track, the power to the train supplied via clip in conduit. There were working colour light signals that controlled the trains, point motors, lights, and lifting crossing barriers. I am sure most members are familiar with this incarnation of Lego Trains.



[http://www.szarafinski.net/stephan/img\\_2242.jpg](http://www.szarafinski.net/stephan/img_2242.jpg)

*One of the 1980 series conduit powered Lego trains, showing the 12v transformer*

I would have loved to have eventually bought some of it, but for reasons I am still not 100% sure of, I never did. It was a very fun system indeed and lasted around 10 years, before it was substantially revised again.

However, it was only when I looked back upon the range through catalogues and from research on the internet that I realised that there was a heck of a lot I did not know about the history of Lego Trains.

Now I had assumed that the conduit powered trains that I saw back in 1980 were the first that Lego made that were track powered. WRONG. The first Lego trains to be powered by conduit actually date back to 1969! They were 12v as opposed to the 4.5v battery powered versions, but used the same motor block, but containing a different motor. The pick-up studs plugged in where my signal control block had gone!

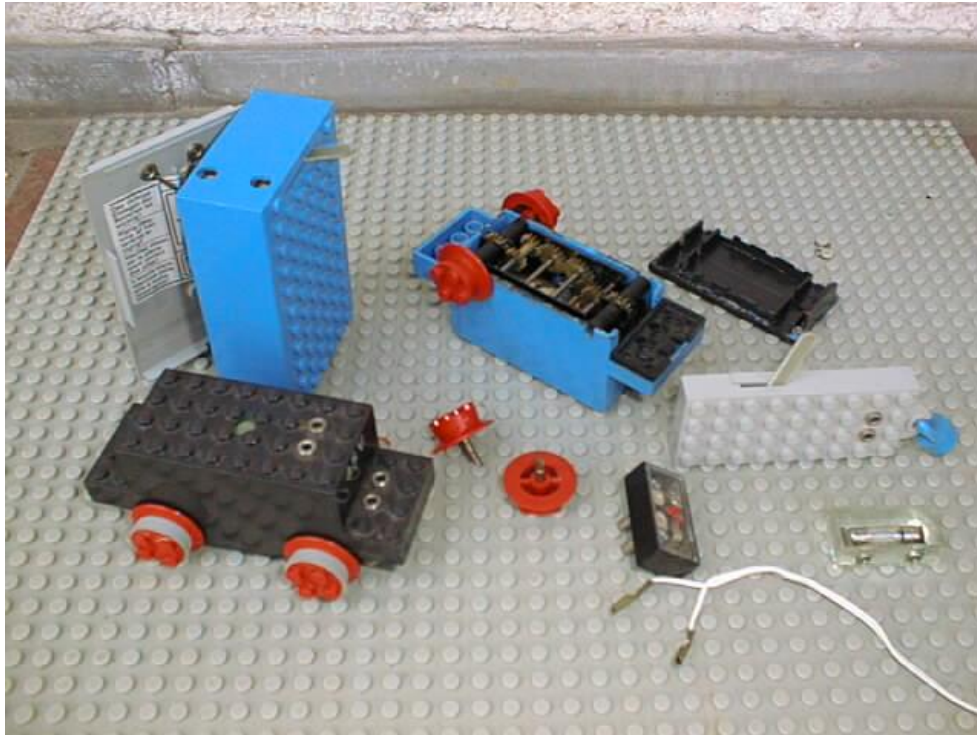

<http://www.brickshelf.com/cgi-bin/gallery.cgi?i=2636830>

*Two early motors, showing one opened up to reveal the gearing. The plug in Signal Control Brick is just above the wires and the Grey Reversing switch mentioned elsewhere in this article is standing behind that.*

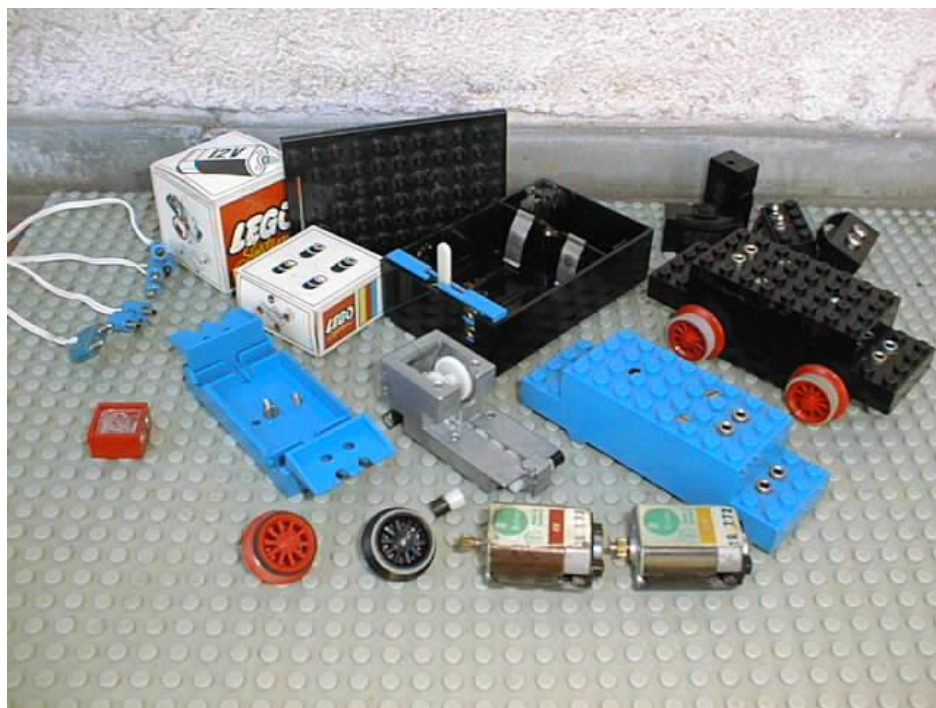

<http://www.brickshelf.com/cgi-bin/gallery.cgi?i=2636831>

*Second Generation Lego Train Motors, showing the lower height and different gearing. At the very rear some of the plug in studs that enable current collection from the clip in conduit. The same motor gearing and casing was used for 4.5V battery trains or 12V track powered trains, the only difference was which actual motor was installed. These are shown in the front of the image and were available as spares to allow you to upgrade a 4.5v to a 12v unit*

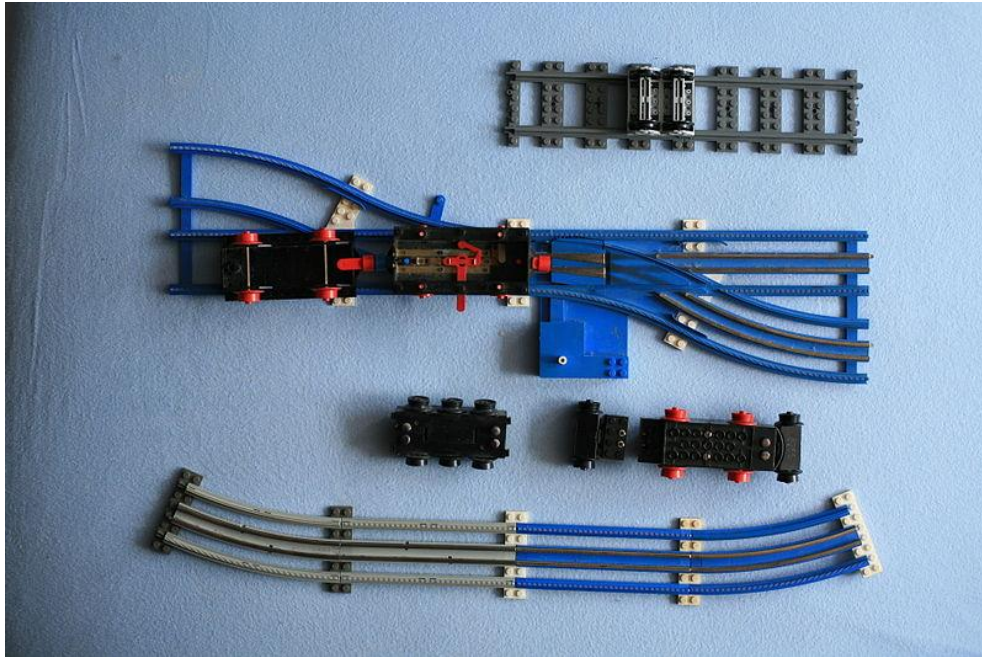

<https://commons.wikimedia.org/wiki/File:DifLegoTrain.jpg>

An Image showing different types of Lego track and motors. Of note are rails from the Blue Battery and Blue Conduit periods and the Grey Conduit track

## Reversing Switch

Also Lego had a device similar to the Big Big Train reversing switch, which was activated by trackside trips. This was nowhere near as elaborate as the Tri-ang one, and the trips were just a couple of pairs of pegs that clipped to the edge of the sleepers.



Copyright © 2012 Vectis Auctions. All Rights Reserved.

[http://www.vectis.co.uk/AuctionImages/423/1125\\_1.jpg](http://www.vectis.co.uk/AuctionImages/423/1125_1.jpg)

This image from an auction catalogue shows a Big Big Train set with both a signal and a reversing switch. The signal containing a lever that would engage with the and stop the train when it was set to danger.



*The reversing lever had various settings and could stop or reverse a train depending on how it was set and which side of the track it was on.*

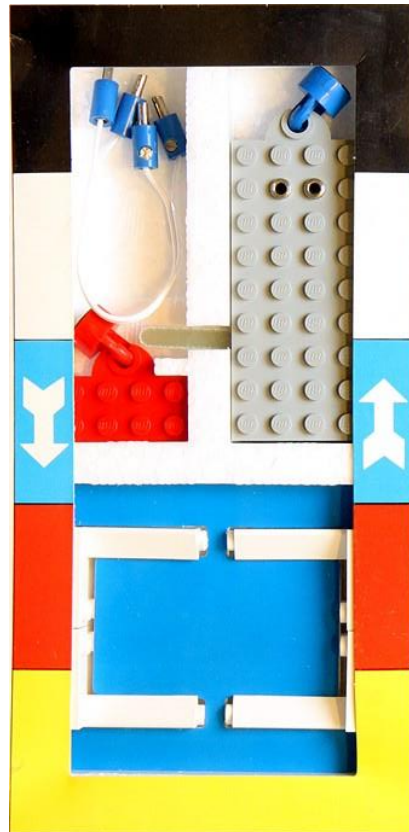
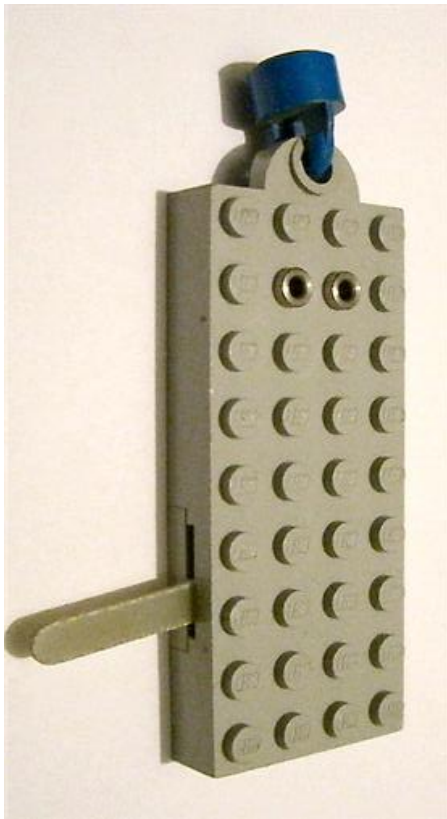

*This is the early version of the reverser, which clipped under the battery box and made an electrical connection to it by way of the metal studs. A pair of wires then ran from this unit to the loco. It was sold separately and in the 119 Super Train Set.*

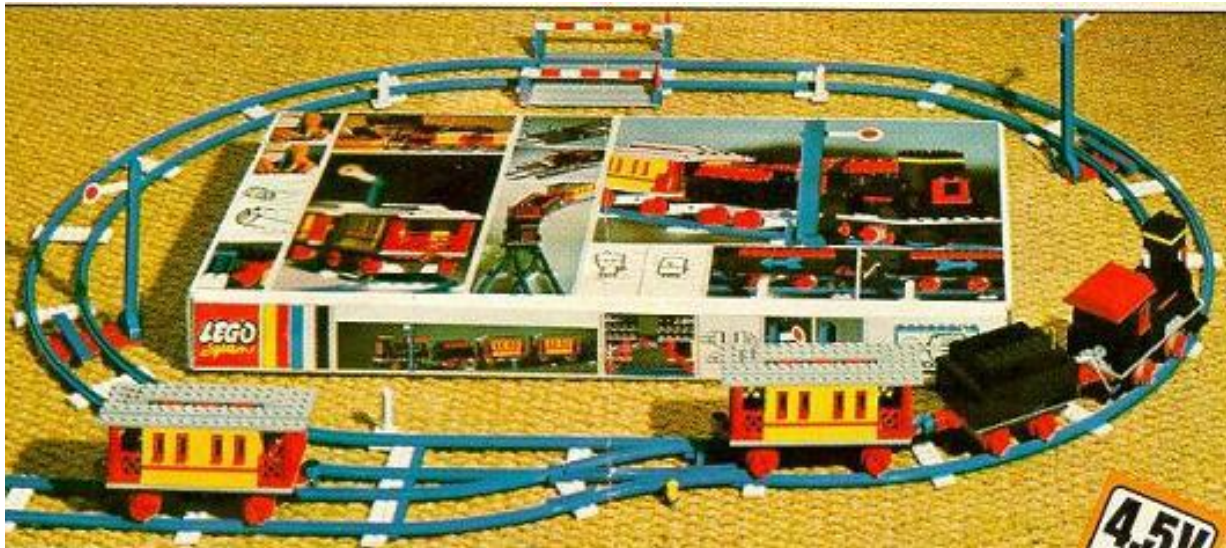

<https://img.bricklink.com/SL/119-1.jpg>

*The 119 super train set. As well as the reverser device this also came with a pair of Signals and the clip on control module, so the train could be stopped, started or reversed automatically. A lot of play value here!*

The device could originally only reverse, and was mounted underneath the battery box, when it was used as a loco tender. The reversing device connected to the battery box automatically and then wires from the device ran to the motor. The protruding switch arm engaged with the peg as the train approached and it reversed. It was later incorporated into a Battery van, which included the mechanism previously supplied separately in the brick sized signal control module too: So now you could reverse from a track side trip or Stop/Start at one of the Lego Signals. This was much better!



<http://www.bricktrains-sets.com/images/picture%2052.jpg>

*The later Battery Van showing one of the trips that engaged with the lever.*



[http://bricker.ru/images/parts/x488c01\\_7.jpg](http://bricker.ru/images/parts/x488c01_7.jpg)

*Inside and underside the battery van*

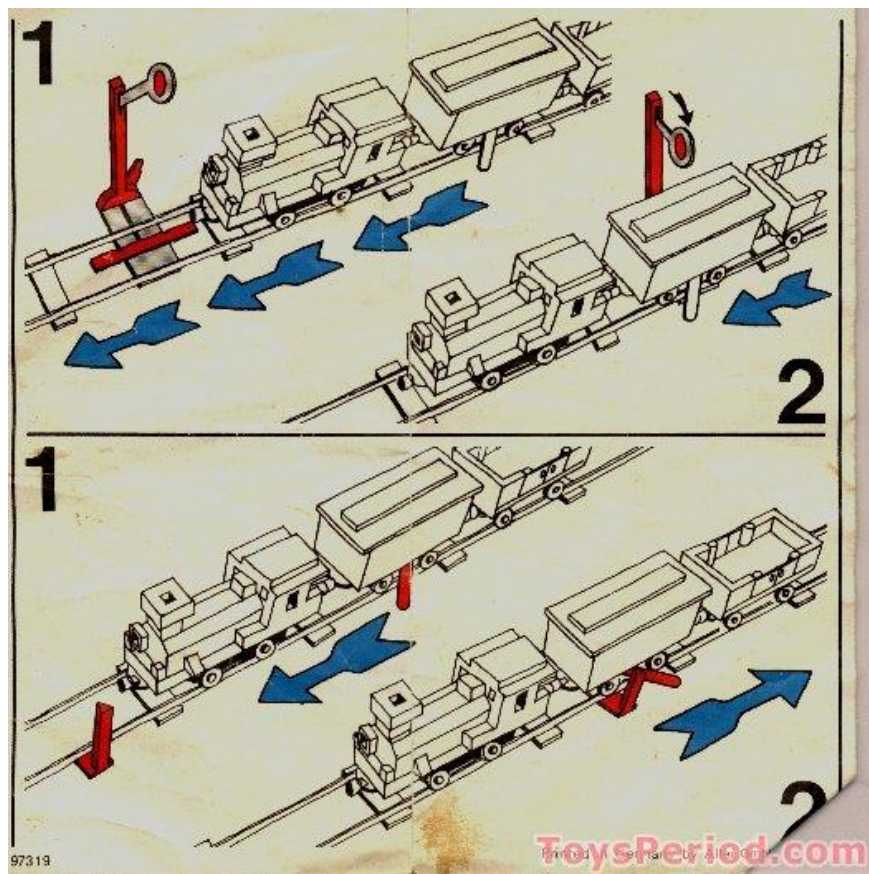

*How it works! You will be relieved to know that the set came with several reversing trips to allow you to shuttle your train up and down.*



*One of the reversing pegs - these came in white and later in red*

I never recall seeing either the simple reverser or the conduit powered trains catalogued or offered for sale in the UK. Can any super Lego enthusiast enlighten us on these issues?

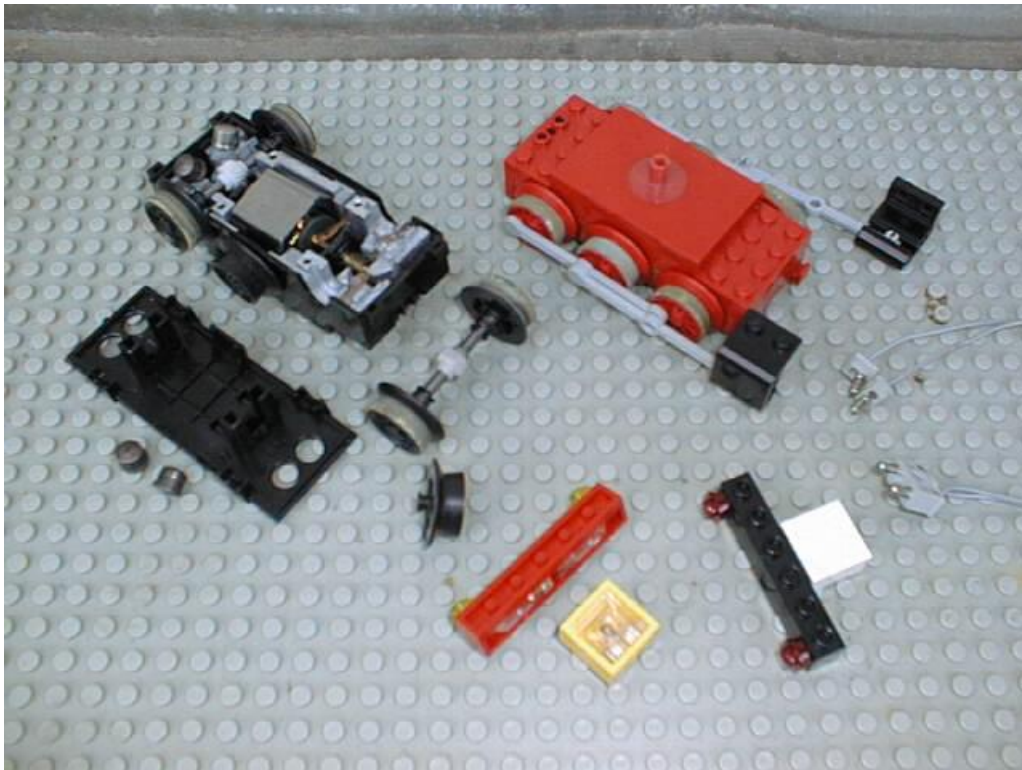

<http://www.brickshelf.com/cgi-bin/gallery.cgi?i=2636833>

*The 1980 series Lego Train Motor Blocks for the new generation of track powered trains. These are 12v and had the collector studs built in.*

### **What is the Point?**

Now back in 1980 when the conduit trains with grey track appeared, there were electric uncoupling rails, lifting crossing barriers, and electrically operated points and these all shared a common motor, the '7863'. Now I assumed that this motor was another Lego first, but WRONG AGAIN! The earlier blue tracked conduit powered trains also had a point motor which came with a special three wire lead. This earlier

motor was a solenoid, but the new one was something rather special and as far as I know, this really was a first!

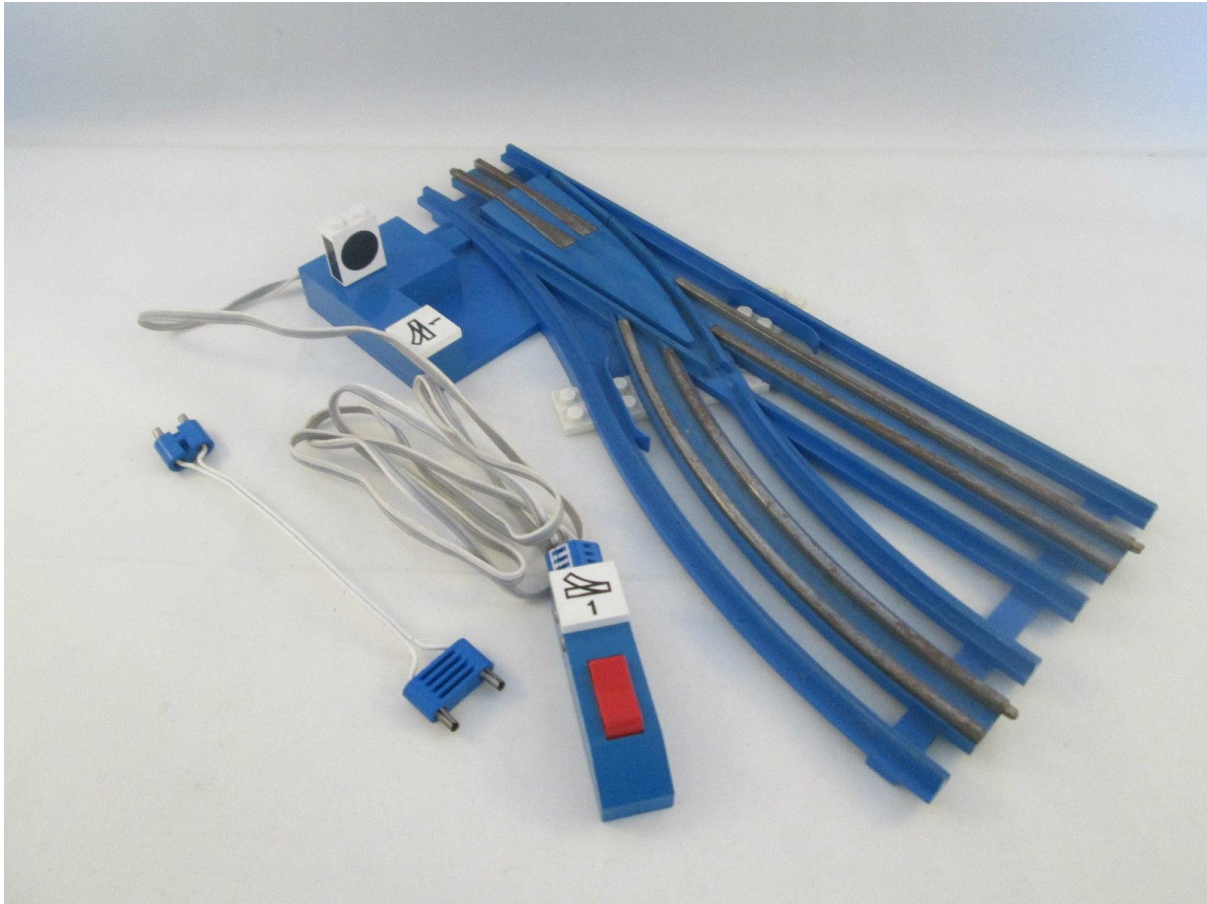

*An earlier Blue Electric period electrically operated LEGO point. The lead connecting the point to the switch has three wires. The mechanism was a solenoid.*

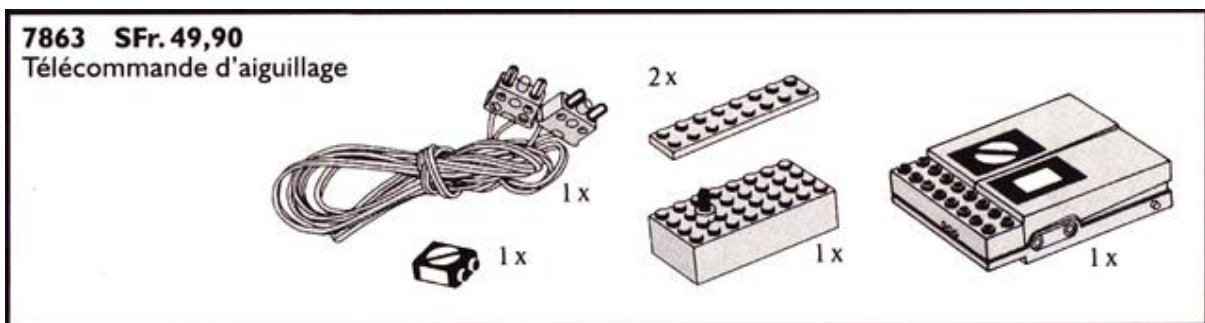

<http://lego.wikia.com/wiki/File:7863-2.png>

*An illustration of the contents of 7863 set*

# Accessoires du train LEGO® 12 volts.



Toutes les boîtes sont disponibles jusqu' à la fin 1993 auprès du service des pièces détachées LEGO®.

<p><b>7865 SFr. 43,90</b> Moteur pour trains 12 V incl. frotteurs</p>				<p><b>5061 SFr. 9,50</b> Fils conducteurs 75 et 25 cm</p>	<p><b>5062 SFr. 12,20</b> Inverseur de marche, signal</p>	<p><b>5063 SFr. 12,00</b> Alimentation pour rails conducteurs 12 V</p>	<p><b>5064 SFr. 5,10</b> Roues de locomotive</p>	
<p><b>7850 SFr. 11,90</b> 8 paires de rails rectilignes</p>	<p><b>7851 SFr. 11,90</b> 8 paires de rails courbes</p>	<p><b>7852 SFr. 14,90</b> 1 paire d'aiguillages 4,5 V</p>	<p><b>7854 SFr. 11,90</b> 8 conducteurs de courant rectilignes 12 V</p>	<p><b>5065 SFr. 13,70</b> Fil conducteur de 3 m avec prises à double broche</p>	<p><b>5066 SFr. 7,20</b> Tampons et attelages</p>	<p><b>5067 SFr. 4,60</b> Bandages caoutchouc</p>	<p><b>5068 SFr. 7,60</b> Châssis locomotive, attelages</p>	
<p><b>7855 SFr. 11,90</b> 8 conducteurs de courant courbes 12 V</p>	<p><b>7856 SFr. 33,90</b> 1 paire d'aiguillages à commande manuelle 12 V</p>	<p><b>7857 SFr. 13,90</b> Croisement 12 V</p>	<p><b>5069 SFr. 7,60</b> Briques lumineuses 12 V</p>	<p><b>5070 SFr. 5,10</b> Essieux</p>	<p><b>5071 SFr. 5,10</b> Essieux avec grandes roues</p>	<p><b>5072 SFr. 4,60</b> Plaque de base 6x28 tenons</p>	<p><b>5073 SFr. 4,00</b> Eclairages pour train LEGO</p>	
<p><b>7858 SFr. 47,90</b> Aiguillage télécommandé à droite 12 V</p>	<p><b>7859 SFr. 47,90</b> Aiguillage télécommandé à gauche 12 V</p>	<p><b>7860 SFr. 47,90</b> Signal lumineux 12 V télécommandé</p>	<p><b>5074 SFr. 4,60</b> Plaques pour boggies</p>	<p><b>5075 SFr. 29,30</b> Tender porte-piles</p>	<p><b>5076 SFr. 3,40</b> Plaques 2x8</p>	<p><b>5077 SFr. 4,20</b> Portes coulissantes et rails</p>	<p><b>5079 SFr. 17,90</b> Boîtier de commande d'aiguillage</p>	
<p><b>7861 SFr. 22,90</b> Assortiment d'éclairage 12 V</p>	<p><b>7864 SFr. 94,50</b> Transformateur universel 220 V/0-12 V</p>	<p><b>7867 SFr. 24,90</b> 4 lampadaires 12 V</p>	<p><b>5080 SFr. 17,90</b> Télécommande pour aiguillage</p>	<p><b>5081 SFr. 16,00</b> Télécommande pour coupe-circuit</p>	<p><b>5082 SFr. 16,00</b> Clignoteur pour passage à niveau</p>	<p><b>5083 SFr. 16,00</b> Télécommande pour croisement</p>	<p><b>5084 SFr. 4,20</b> Brique lumineuse</p>	<p><b>5085 SFr. 5,10</b> Alimentation pour rails conducteurs, droite (12 V)</p>
<p><b>7863 SFr. 49,90</b> Télécommande d'aiguillage</p>	<p><b>5200 SFr. 5,50</b> Mâts de signaux, pieds de mâts</p>							

[http://vignette2.wikia.nocookie.net/lego/images/4/4e/CH\\_catalog\\_train\\_12V\\_p2\\_lr.jpg/revision/latest?cb=20120116174916](http://vignette2.wikia.nocookie.net/lego/images/4/4e/CH_catalog_train_12V_p2_lr.jpg/revision/latest?cb=20120116174916)

A couple of pages from a Swiss leaflet that shows much of the LEGO 1980 series items.

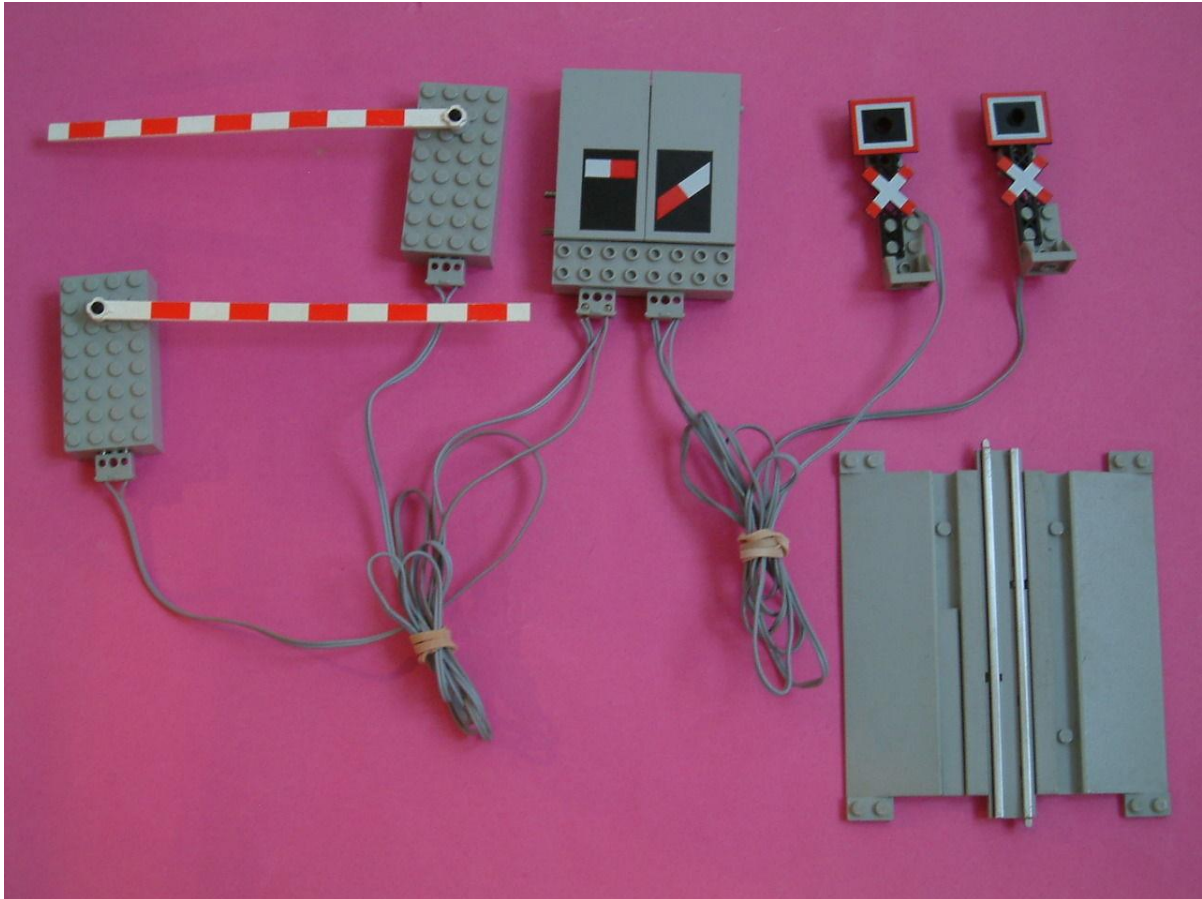

An incomplete level crossing set recently listed on e-bay - The barriers have been fitted directly to the top drive of 7863 motors.

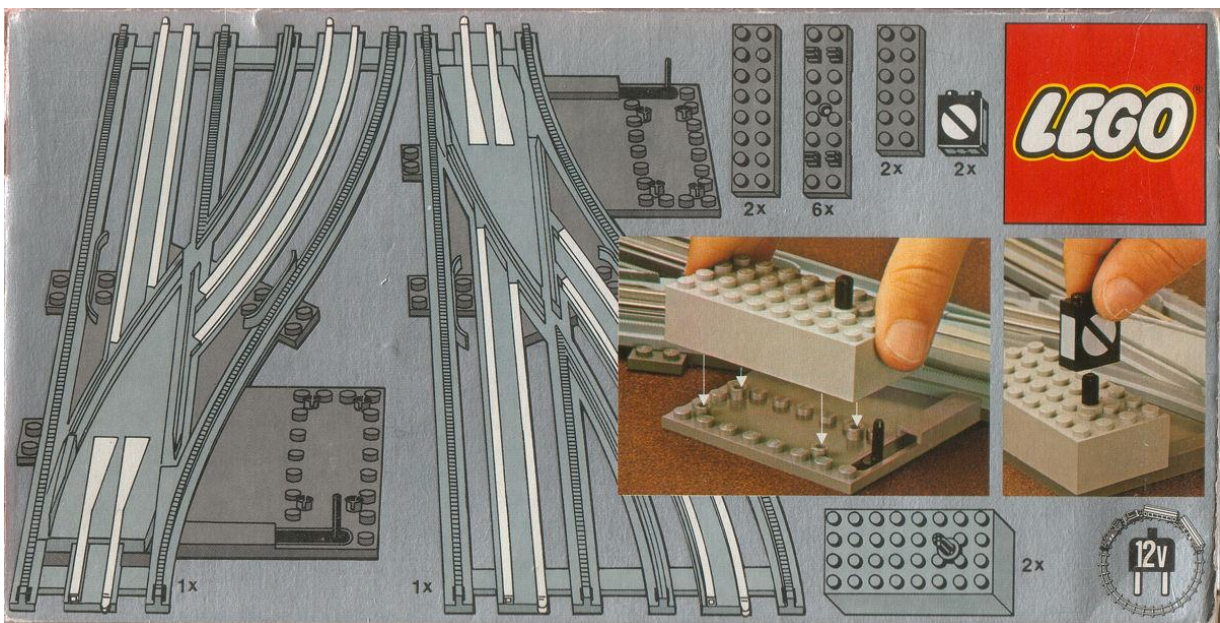

The box of an electric point also offered recently on e-bay. The 7863 Point motor engages over the tie bar and the dummy lantern goes on the top drive to show which way the point is set. In this case the box being fitted is the manual one, but the electric one fitted in the same way.



*Instructions for the electrically operated points showing the switches connected to the Lego transformer and the two wire connections to the motors.*

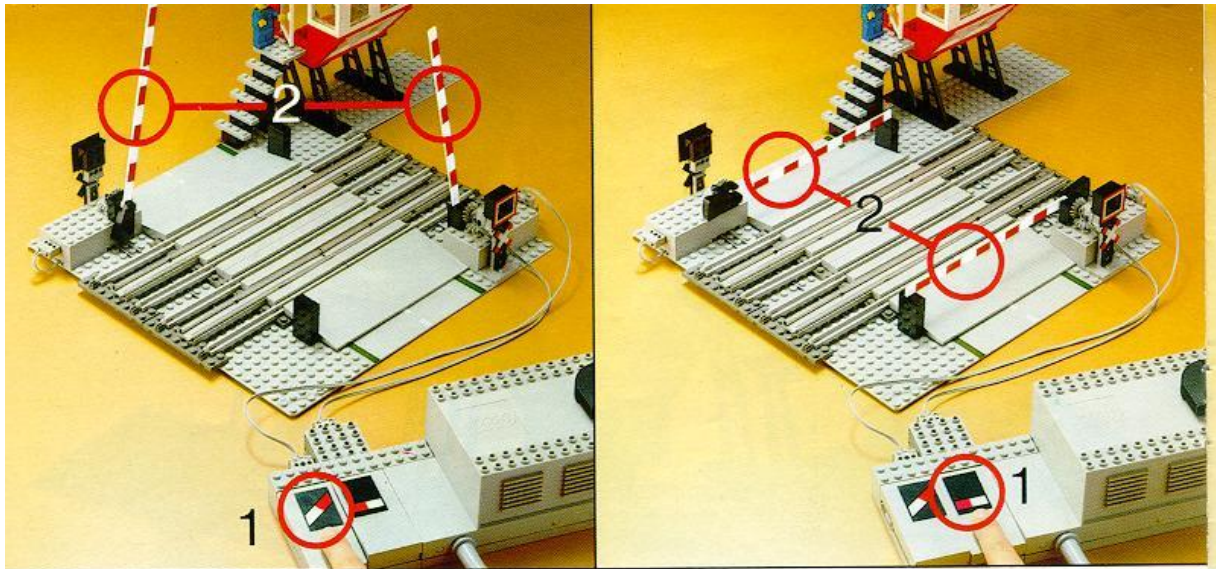

- 🇩🇰 Sådan skal den fjernbetjente baneoverskæring fungere.**  
 Hvis du trykker på knappen, der viser bom oppe, så går begge bommene op.  
 Hvis du trykker på knappen, der viser bom nede, så går begge bommene ned, og signalet blinker.
- Fejlfinding.**  
 Hvis baneoverskæringen ikke fungerer, som den skal, så prøv at finde fejlen ved hjælp af det efterfølgende eller undersøg, om du har bygget rigtigt efter vejledningen.
- 
- 🇸🇪 Så här fungerar den fjärrstyrd järnvägsövergången.**  
 Om du trycker på knappen, som visar att bommen är uppe, så går båda bommarna upp.  
 Om du trycker på knappen, som visar en nerfälld bom, så går båda bommarna ner och signalen blinkar.
- Felsökning.**  
 Om järnvägsövergången inte fungerar som den skall, så försök finna felet med hjälp av det efterföljande eller undersök om du har byggt riktigt efter vägledningen.
- 
- 🇫🇮 Näin toimii kauko-ohjattu tasoristeys.**  
 Kun painat kosketinta, johon on kuvattu puomi yläasennossa, puomi nousee.  
 Kun painat kosketinta, johon on kuvattu puomi ala-asennossa, puomit laskeutuvat ja opastinvalo vilkkuu.
- Vian paikallistaminen.**  
 Jos tasoristeys ei toimi niinkuin pitäisi, yritä paikallistaa vika allaolevalla tavalla tai varmista, että olet rakentanut kaiken ohjeiden mukaisesti.
- 
- 🇬🇧 Operating the remote controlled level crossing.**  
 Press the "barrier closed" key and both barriers will lower and the red light will flash.  
 Press the "barrier raised" key and both barriers will lift and the light will stop flashing.
- 🇺🇸 Troubleshooting.**  
 If the barrier does not operate correctly check first that you have assembled it properly, then proceed as follows.
- 
- 🇫🇷 Fonctionnement du passage à niveau.**  
 Si vous appuyez sur la touche où sont représentées les barrières levées, les deux barrières se lèvent.  
 Si vous appuyez sur la touche où sont représentées les barrières baissées, les deux barrières se baissent.
- Mauvais fonctionnement.**  
 Si le passage à niveau ne fonctionne pas correctement, essayez de découvrir la cause en suivant les instructions ci-dessous, ou vérifiez que vous avez bien suivi les instructions de montage.
- 
- 🇳🇱 Zo bedienen je de spoorbomen op afstand!**  
 Beide spoorbomen gaan omhoog als je drukt op de schakelaar waarop de spoorbomen "omhoog" staan afgedrukt.  
 Druk je op de schakelaar met de spoorbomen "omlaag" dan gaan beide spoorbomen naar beneden en is de overweg vrij voor de trein en gesloten voor het weg-verkeer.
- Zoek de fout.**  
 Als de overweg niet goed werkt kun je de fout mogelijk opsporen door nogmaals de bouw-instructie na te kijken of de volgende aanwijzingen op te volgen.
- 
- 🇩🇪 So sollte der ferngesteuerte Bahnübergang funktionieren.**  
 Wenn man auf den Knopf drückt, der die Schranke öffnet, sollten beide Schrankenbalken nach oben gehen.  
 Drückt man auf den Knopf, der die Schranke schließt, sollten beide Schrankenbalken nach unten gehen.
- Aufspüren von Fehlerquellen.**  
 Sollte der Bahnübergang nicht richtig funktionieren, kann man mit den folgenden Instruktionen versuchen, den Fehler zu finden. Außerdem sollte man prüfen, ob man die Bauanleitungen genau befolgt hat.
- 
- 🇮🇹 Ecco come deve funzionare il passaggio a livello automatico.**  
 Se azioni il pulsante che indica sbarre alzate entrambe le sbarre si alzano.  
 Se azioni il pulsante che indica sbarre abbassate entrambe le sbarre si abbassano.
- Ricerca guasti.**  
 Se il passaggio a livello non funziona correttamente cerca di individuare il guasto seguendo le istruzioni più sotto indicate e controlla se hai montato tutto come indicato dalle istruzioni.
- 
- 🇪🇸 Así es como debe funcionar el paso a nivel a control remoto.**  
 Si pulsas el botón que tiene una flecha señalando hacia arriba, las dos barreras subirán.  
 Si pulsas el botón que tiene una flecha señalando hacia abajo, las dos barreras bajarán.
- Posibles fallos.**  
 Si el paso a nivel no funciona debidamente, comprueba si has seguido las instrucciones de montaje correctamente. Si es así y aún no funciona, sigue estas instrucciones.

*The debugging section from the Electric level crossing instructions!*

The first thing you notice about the 7863 point motor is that it only has two wires. Why? Well it is a rather clever motor as it is permanent magnet rotor that deflects when the coil within which it sits in is energised. This gives the rotary movement.



<http://www.brickshelf.com/cgi-bin/gallery.cgi?i=2636834>

*The insides of a Lego 7863 Point motor. The two wire connection to the coil can clearly be seen. This is no solenoid! Unfortunately the top pole piece hides the armature and the gearing. I would love the opportunity to open one of these up and examine it further.*

All Lego electrical accessories for the 1980 train series were powered by a 12v DC take off from the Lego transformer, so it appears that the motor was fed with a short burst of full wave DC when you pressed one switch and the polarity was reversed when you pressed the other. This was quite cunning stuff.

So let's now go forward to 1983 and Lehmann introduces a new modular point motor to replace the rather nasty solenoids that have been in the LGB range since the early 1970s. This motor can have a two pole double throw switch module plugged into it to control trains and a point lantern added the sides to show how it is set. Most significantly it has a two wire feed, because this too is a permanent Magnet rotor operating with a coil that deflects it to give the drive.

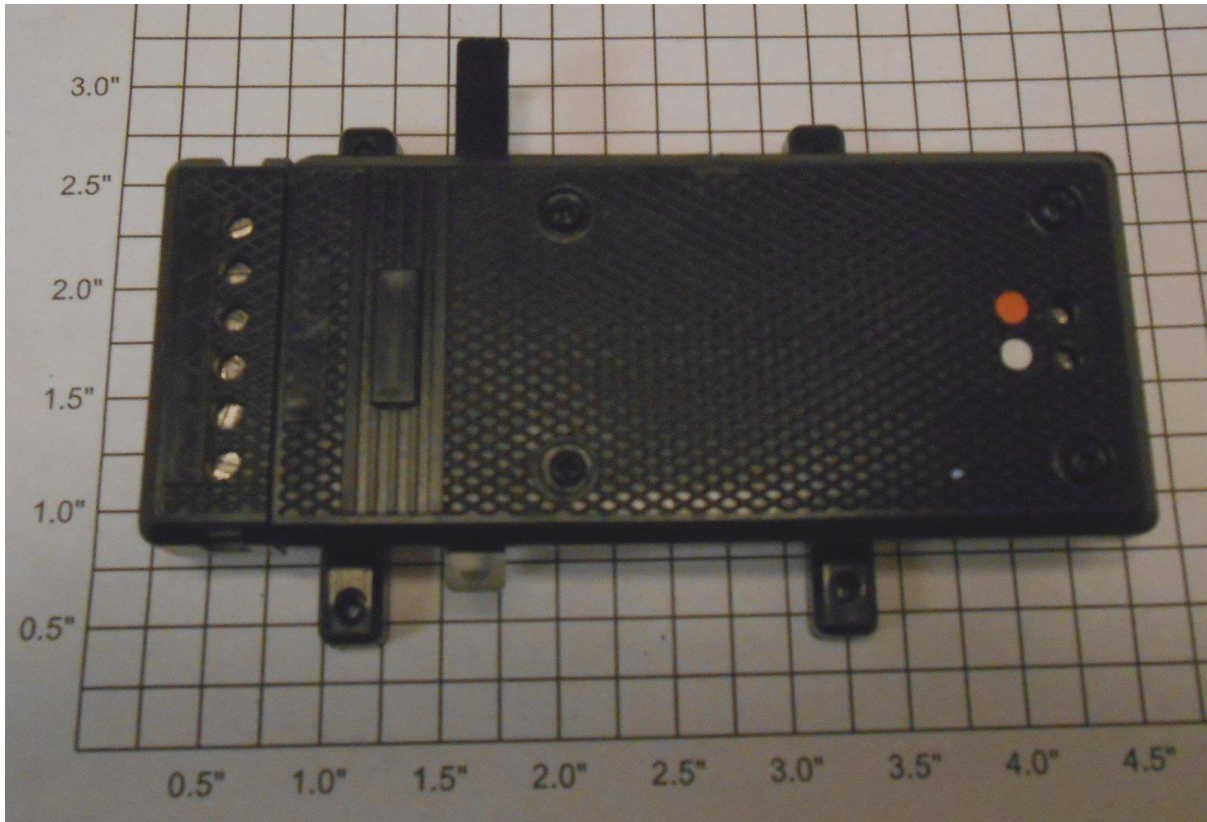

[http://trainz.co/robophoto/2014/04/22/20140422-123839-C2-Trainz-P11982149\\_199XXX-.JPG](http://trainz.co/robophoto/2014/04/22/20140422-123839-C2-Trainz-P11982149_199XXX-.JPG)

*An LGB 12010 EPL drive with the modern supplementary switch (12070) attached. The drive can go on either side of the point and an illuminated point lantern can be attached on the other side*

LGB made a lot of fuss when they introduced their new point motor - they called it the EPL drive, which was pun on both the company name (at the time) Ernst Paul Lehmann and 'Electromagnetic Polarised Linear'. With a few tweaks to improve reliability, the EPL drive has been in production ever since.

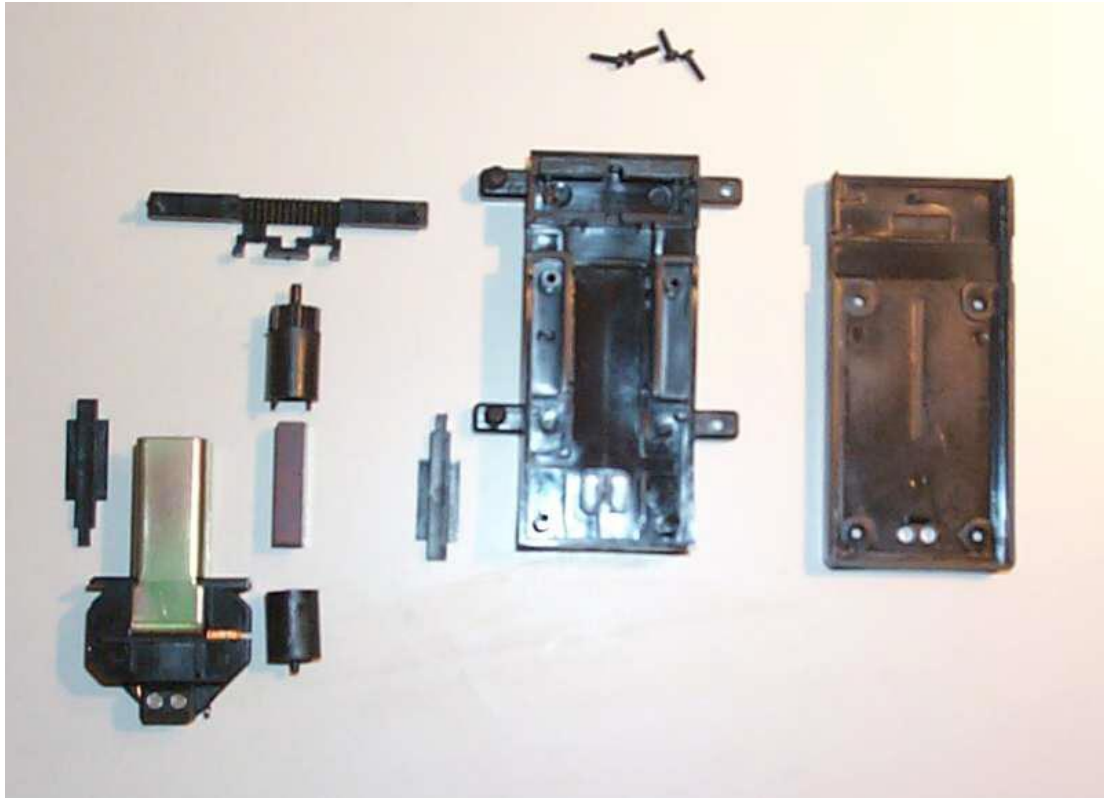

[http://www.beathis.ch/qb/digital/MX81/mx81\\_1.jpg](http://www.beathis.ch/qb/digital/MX81/mx81_1.jpg)

*An exploded view of an EPL Drive*



[http://www.trainelectronics.com/articles/AutomaticBlockSwitchController/Part\\_2\\_turnout\\_motors/images/LGB\\_all\\_parts.JPG](http://www.trainelectronics.com/articles/AutomaticBlockSwitchController/Part_2_turnout_motors/images/LGB_all_parts.JPG)

*The EPL Coil with the Pole pieces attached, the bar magnet and two part case that houses the magnet, showing the gear drive for the rack.*

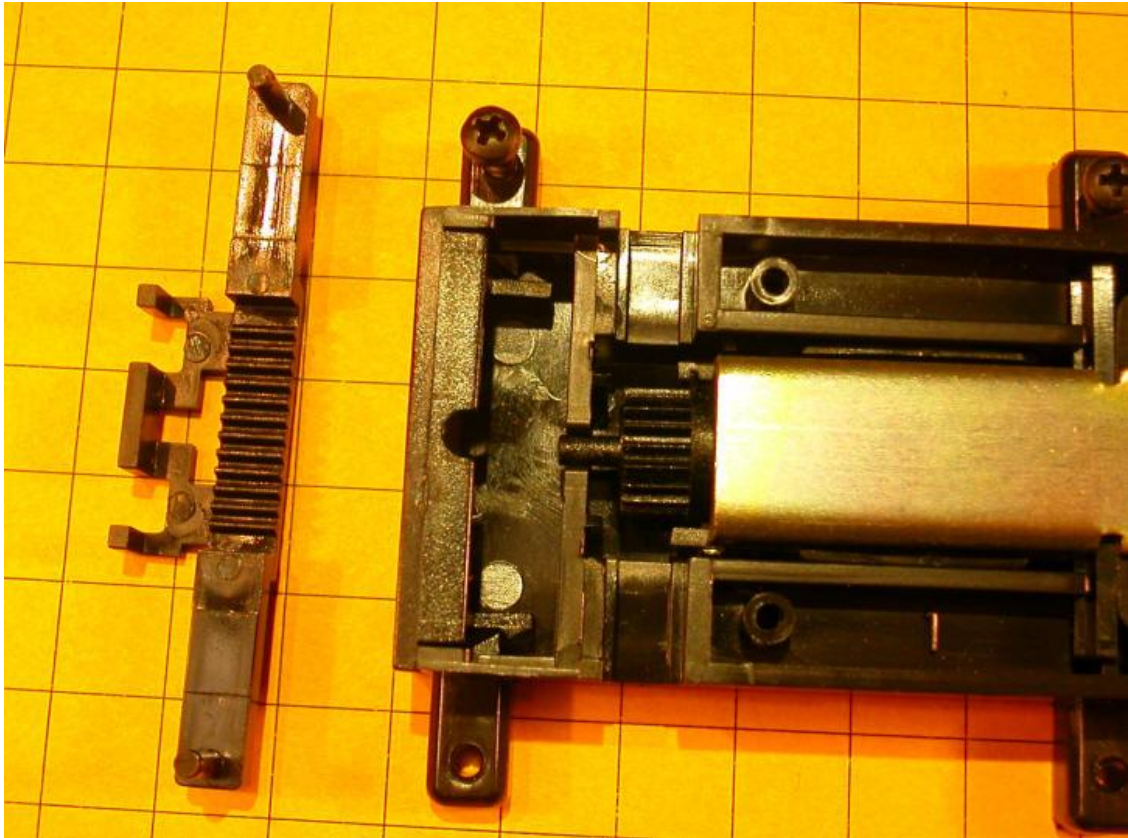

[http://www.trainelectronics.com/articles/AutomaticBlockSwitchController/Part\\_2\\_turnout\\_motors/images/LGB Rack off.JPG](http://www.trainelectronics.com/articles/AutomaticBlockSwitchController/Part_2_turnout_motors/images/LGB Rack off.JPG)

*The EPL Coil and magnet in the housing showing the rack. Of note are two stops on either side of the coil that prevent the rotor from going too far. Notice also the blanking plate at the end which can be removed to fit the 12070 supplementary switch.*

LGB incorporated two big improvements over the Lego versions. They allowed you add a switch, which was very useful to control your trains and add interlocking AND they supplied the drive with a clever combination of full wave AC and Half Wave DC: One terminal of the motor was connected direct to the AC terminal on your transformer, whilst the supply from the other side was fed through one of a pair of diodes before going to the point motor. These turned neat AC into half wave positive or negative DC. The LGB EPL drive type motor worked much the same as the Lego one, but with two real advantages:

Firstly if the supply fed to the motor is half wave the motor will not overheat or burn out. I have accidentally allowed EPL drives to receive constant supply on several occasions, and never burned one out yet. I am fairly sure that if this had been neat DC the result would have been different.

Secondly, the half wave DC control system meant that the motor was very easy to automate via train operated reed switches, or operate via a control box, or a combination of both. As many reeds or switches as you wished could all be connected to just the one input terminal of the point motor! This made it very easy to set up.

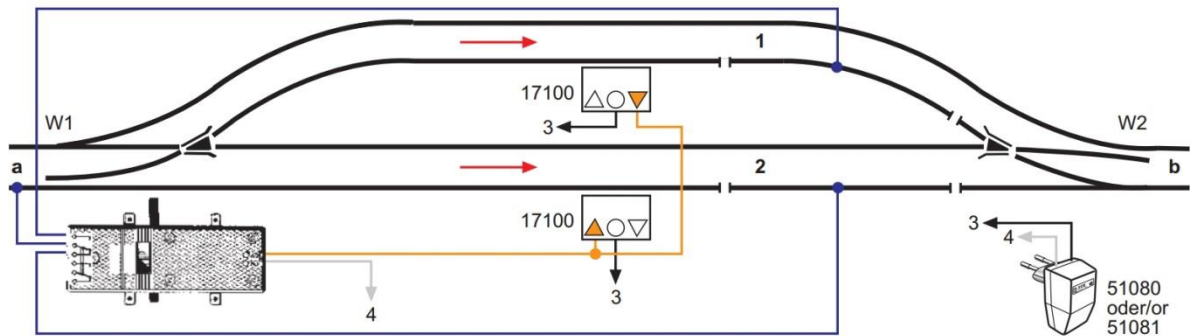

<http://www.gscalene.com/images/information/lgb-epl-alternating-station-circuit.jpg>

*A diagram showing simple automated loop using two reeds and one EPL drive. As one train enters it will stop and release the other.*

*A point control switch box to give manual control could also be easily fed into the orange wire of circuit. Also the separate on/off switch box could be used to allow the supply (black wire) to the reeds to be turned off, giving you manual control instead of automatic. LGB really made wiring their new point motors very simple and easy!*

So, the big questions that need asking here are:

Did Lego copy Tri-ang Big Big Train when they designed their Polarity Reverser Unit, or where other manufacturers already doing this sort of thing?

Did Lehmann copy the Lego 7863 point motor when they designed the EPL drive? I know of no other point motors of this type (apart from the PIKO G scale version which is very recent) , but perhaps you do? If so we would like to hear from you!

Also if anyone has a damaged or broken LEGO 7863, I would like to hear from you, as I would really enjoy either taking it apart, or seeing exactly what is inside!

### **Post Script:**

Lego trains have continued to evolve after the 1980 series, progressing to metal rails and then most recently to on board battery power with radio control (to fit in with European legislation restricting the sale of toys operated by transformers for use by children). Lego trains have a massive following from adults as well as children and the range has included some impressive models, both supplied as kits from the factory, but also the models designed by the enthusiasts themselves.

Although the range no longer includes a point motor, a quick search on the internet will show you how to make one out of Lego Technics parts. A search on the internet can also find you whole sites devoted to running and getting the best out of Lego Trains. They have come a long way since 1967!